

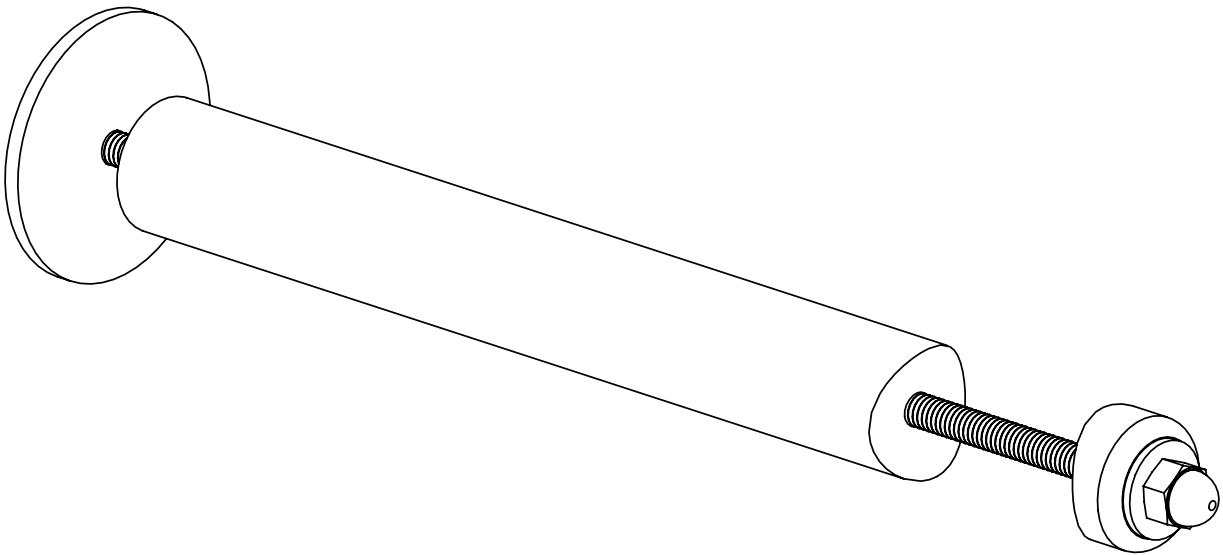

# T-TOP STAND-OFF

## INSTALLATION GUIDE



### NOTE

STAND-OFF'S PROVIDE ADDITIONAL SUPPORT FOR YOUR T-TOP. THEY CONNECT THE LEGS OF THE T-TOP TO THE CENTER CONSOLE.

---

### INSTALLATION SUPPORT

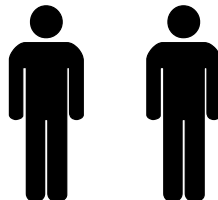

# STRYKER T-TOPS

## PARTS LIST (PER STAND-OFF)

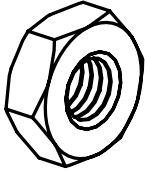

1x

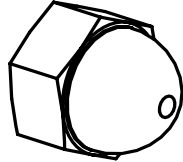

1x

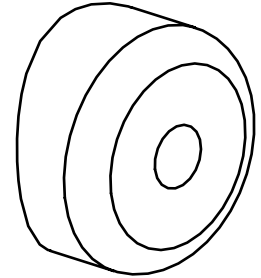

1x

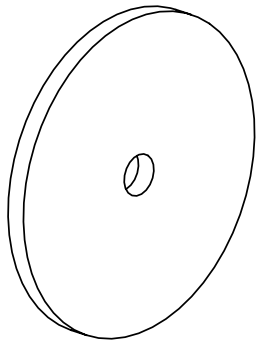

1x

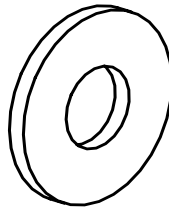

1x

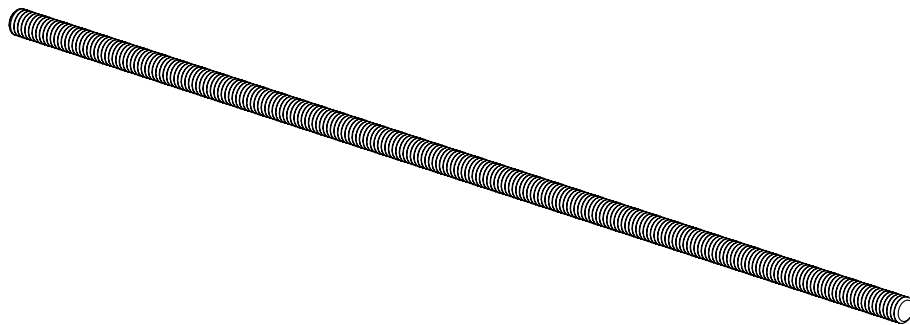

1x

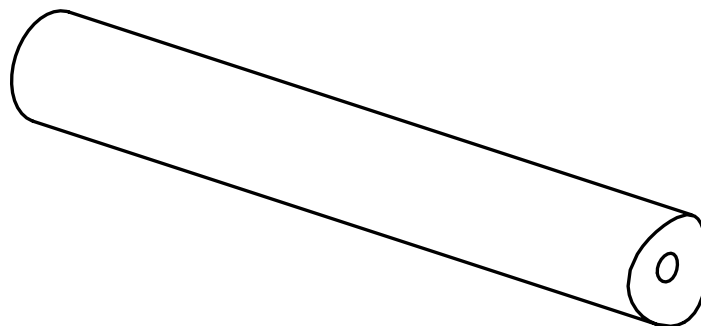

1x

# STRYKER T-TOPS

## EXPLODED VIEW

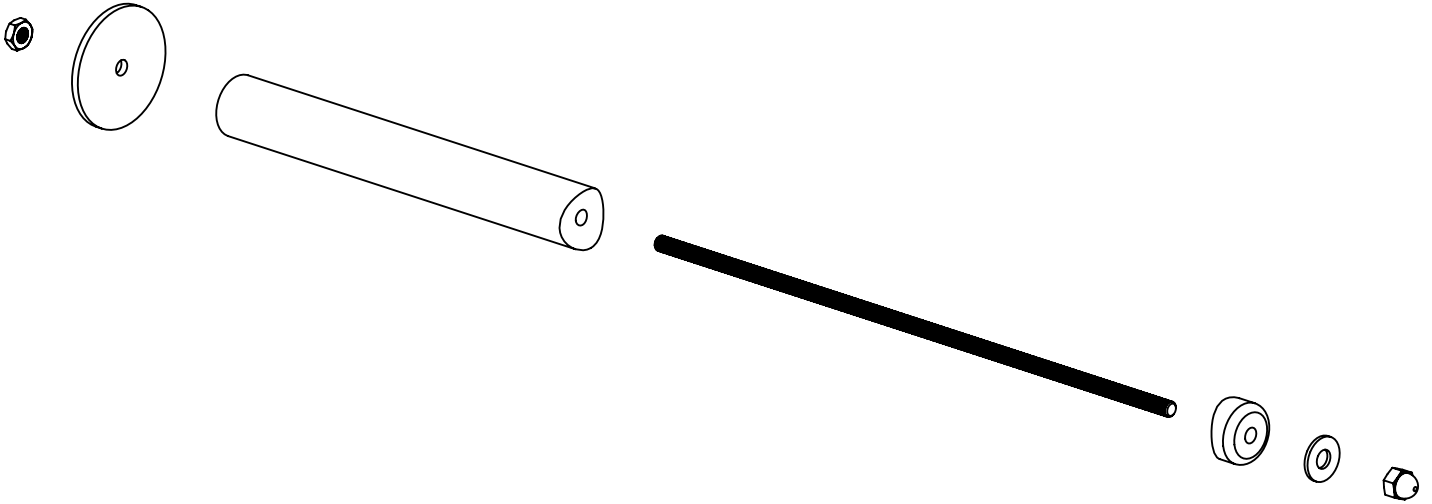

## STEP 1

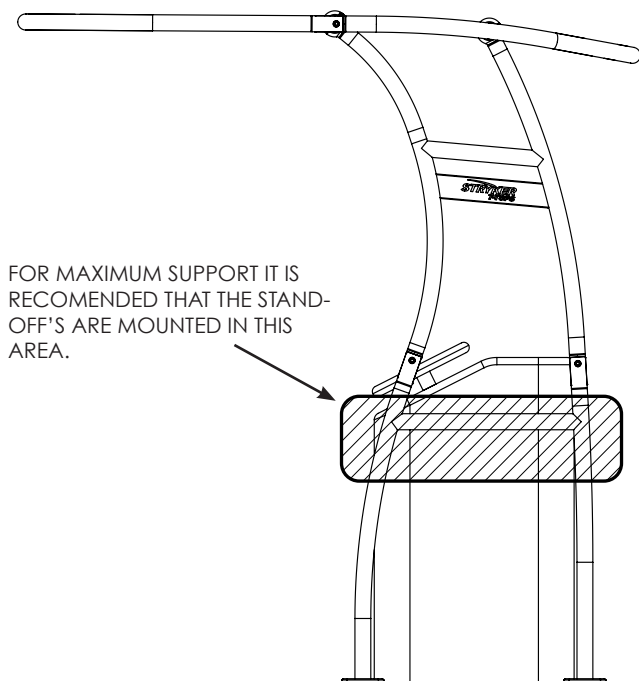

FOR MAXIMUM SUPPORT IT IS RECOMMENDED THAT THE STAND-OFF'S ARE MOUNTED IN THIS AREA.

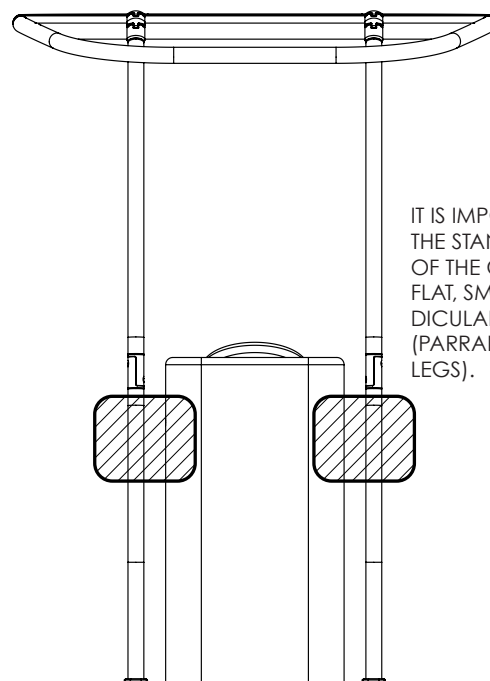

IT IS IMPORTANT TO MOUNT THE STAND-OFF TO AN AREA OF THE CONSOLE THAT IS FLAT, SMOOTH AND PERPENDICULAR TO THE STAND-OFF (PARALLEL WITH THE TOWER LEGS).

# STRYKER T-TOPS

## STEP 2

**\*\*IMPORTANT\*\***

MAKE SURE YOU HAVE ACCESS TO THE INSIDE OF THE CONSOLE IN THE MOUNTING AREA SO THAT YOU CAN TIGHTEN THE STAND-OFF NUT WITH A WRENCH OR SOCKET SET.

MEASURE WIDTH FROM THE MOUNTING SURFACE ON THE CONSOLE TO THE CLOSEST SIDE OF THE T-TOP TUBE.

**\*\*IMPORTANT\*\***

BE SURE TO TAKE THIS MEASUREMENT IN THE DESIRED MOUNTING LOCATION.

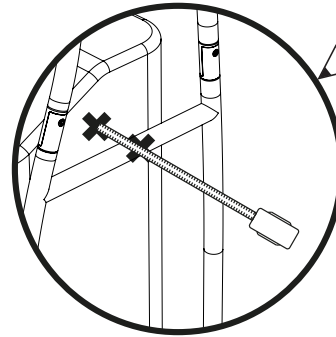
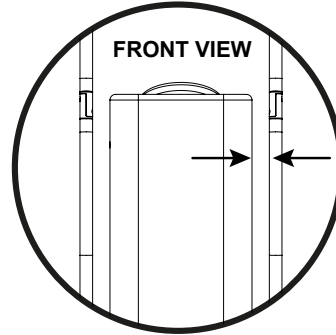
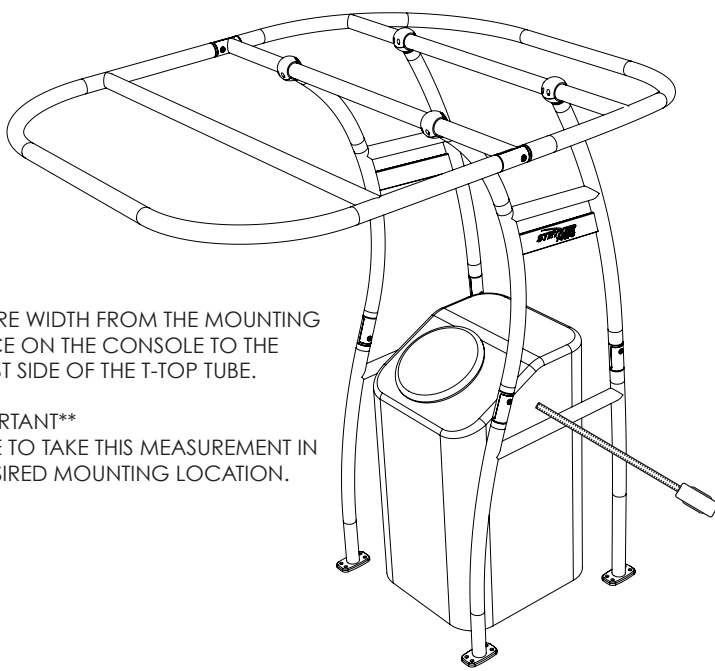

MARK MOUNTING LOCATIONS.

## STEP 3

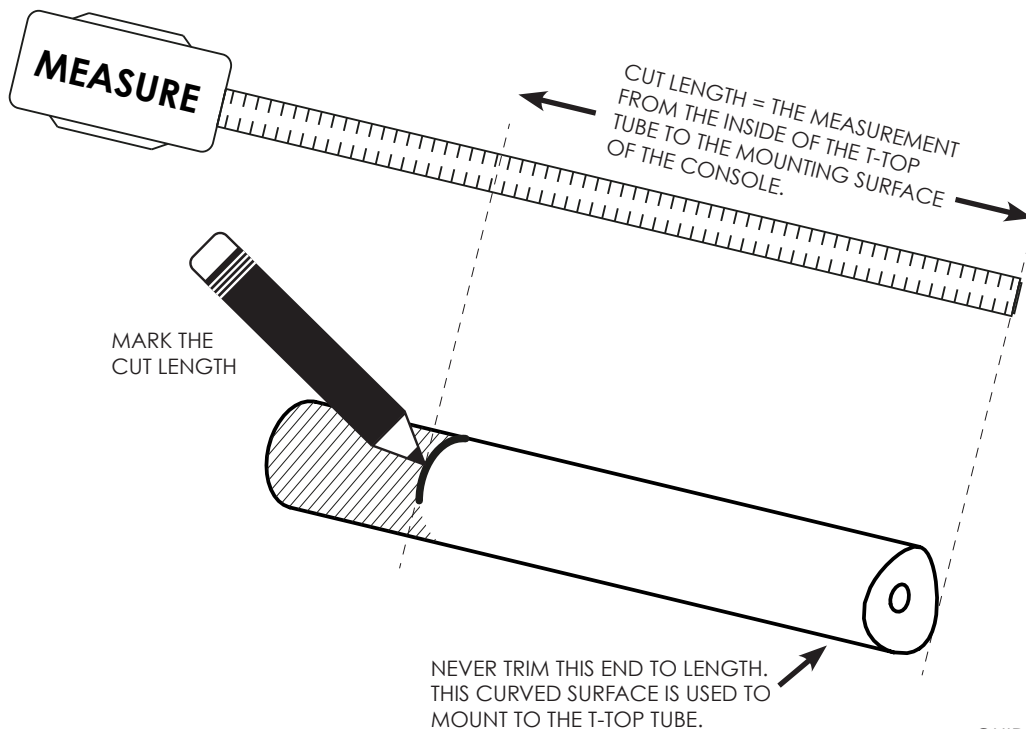

# STRYKER T-TOPS

## STEP 4

CUT THE TUBE ALONG THE MARKED LINE.  
A HACKSAW IS RECOMEND.  
DEPENDING ON THE REQUIRED ANGLE  
A CUTTING JIG MAY BE HELPFUL.

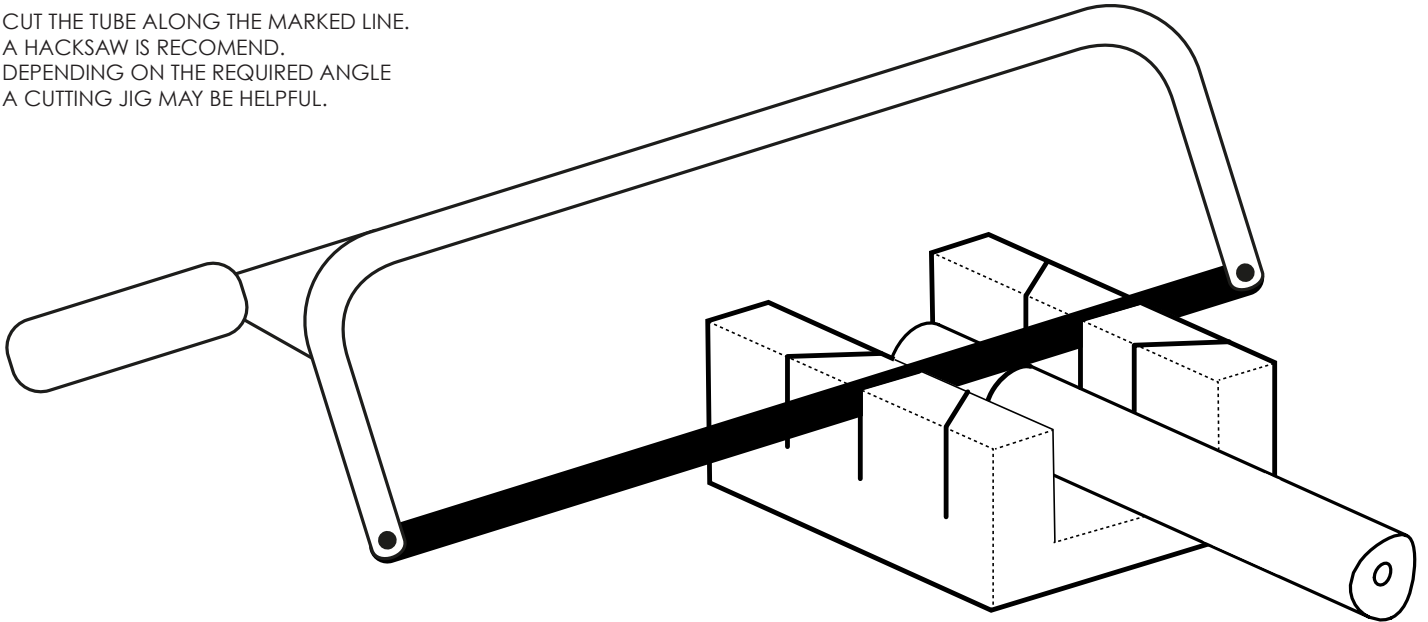

## STEP 5

DRILL HOLES AT MARKED POSITIONS ON  
BOTH THE T-TOP AND THE CONSOLE.

**\*\*IMPORTANT\*\***

MAKE SURE THE HOLES ARE STRAIGHT AND  
ALIGNED SO THAT THE THREADED ROD  
CAN PASS EASILY THROUGH BOTH.

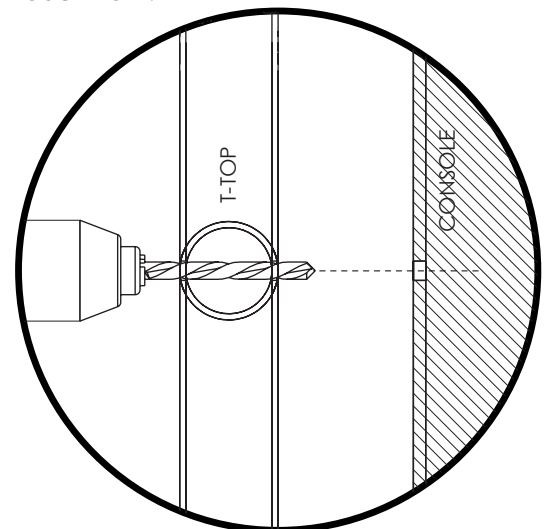
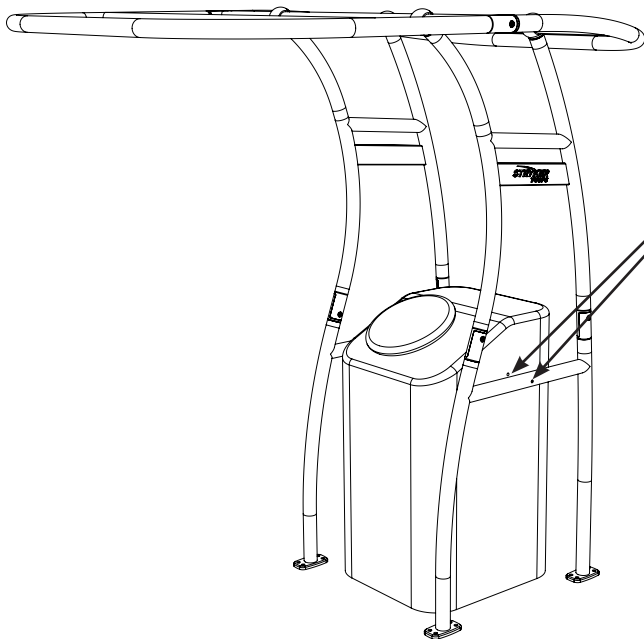

# STRYKER T-TOPS

## STEP 6

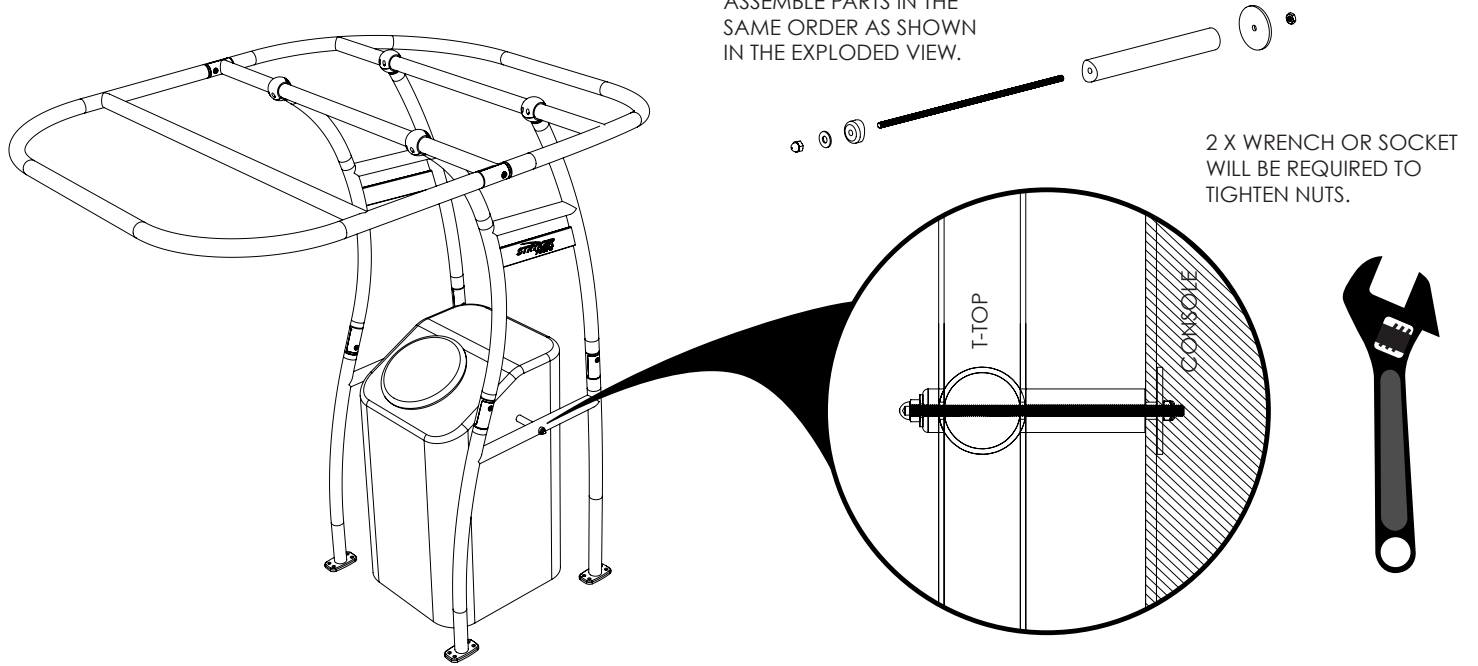

## STEP 7

**REPEAT INSTALLATION PROCESS  
ON BOTH SIDES OF THE T-TOP.**

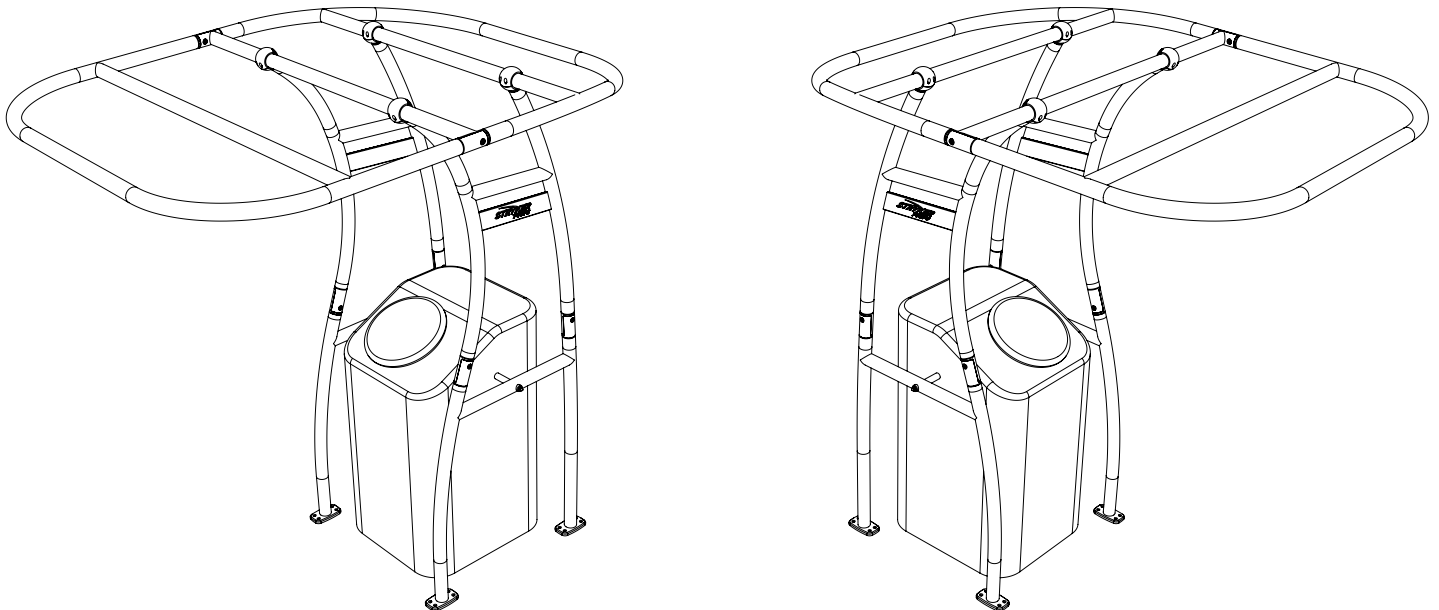



**NOTE: IF YOUR T-TOP REQUIRES ADDITIONAL STABILITY  
PLEASE CONTACT OUR CUSTOMER SERVICE DEPARTMENT  
FOR FURTHER RECOMENDATIONS.**

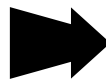

[www.strykertops.com](http://www.strykertops.com)